

CHARACTERISTICS

GENERAL DATA

Focusing Method	Electrostatic
Deflection Method	Magnetic
Deflection Angles (Approx.)	
Horizontal	100 Degrees
Diagonal	114 Degrees
Vertical	83 Degrees
Phosphor	Aluminized P4
Fluorescence	White
Persistence	Medium Short
Faceplate	Gray Filter Glass
Light Transmittance (Approx.)	42 Percent

Types 23DVP4 and 23DZP4 are similar to Types 23MP4 and 23ALP4 respectively, except that they employ the banded tube with coated funnel construction for integral implosion protection, and have reduced faceplate transmittance.

ELECTRICAL DATA

	23DZP4	23DVP4	
Heater Voltage	6.3	6.3 Volts	
Heater Current $\pm 5\%$	0.45	0.60 Ampere	
Heater Warm-up Time ¹	11	11 Seconds	
Direct Interelectrode Capacitances (Approx.)			
Cathode to All Other Electrodes		5 pf	
Grid No. 1 to All Other Electrodes		6 pf	
External Conductive Coating and Rim Band to Anode ²		2500 pf	Max.
		1700 pf	Min.

MECHANICAL DATA

Minimum Useful Screen Dimensions (Maximum Assured)	
Height	15 ¹ / ₈ Inches
Width	19 ¹ / ₄ Inches
Diagonal	22 ⁵ / ₁₆ Inches
Minimum Useful Screen Area	282 Sq. Inches
Neck Length	5 ¹ / ₈ \pm ¹ / ₈ Inches
Overall Length	14 ⁷ / ₁₆ \pm ⁵ / ₁₆ Inches
Bulb Contact (Recessed Small Cavity Cap)	J1-21
Bulb	J187L
Base	B7-208
Basing	8HR
Weight (Approx.)	28 Pounds

RATINGS

MAXIMUM RATINGS (Design Maximum Values)

Grid Drive Service³		
Maximum Anode Voltage	22,000 Volts	dc
Minimum Anode Voltage	11,000 Volts	dc
Grid No. 4 Voltage (Focusing Electrode)	-550 to +1100 Volts	dc
Maximum Grid No. 2 Voltage	550 Volts	dc
Minimum Grid No. 2 Voltage	200 Volts	dc
Grid No. 1 Voltage		
Negative Bias Value	155 Volts	dc
Negative Peak Value	220 Volts	
Positive Bias Value	0 Volt	dc
Positive Peak Value	2 Volts	
Peak Heater-Cathode Voltage		
Heater Negative with Respect to Cathode During Warm-up Period Not to Exceed 15 Seconds	450 Volts	
After Equipment Warm-up Period	200 Volts	
Heater Positive with Respect to Cathode	200 Volts	

QUICK REFERENCE DATA

Television Picture Tube
 23" Direct Viewed
 Rectangular Glass Type
 Gray Filter Glass
 Aluminized Screen
 Electrostatic Focus
 114° Magnetic Deflection
 1 1/8" Neck Diameter
 No Ion Trap
 External Conductive Coating
 Banded Tube, Coated Funnel
 23DVP4: 6.3v/600 ma Heater
 23DZP4: 6.3v/450 ma Heater

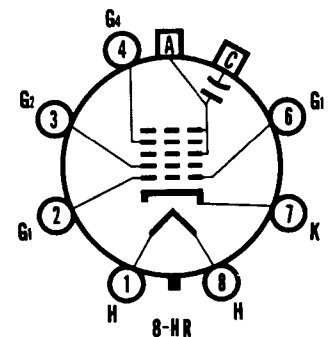
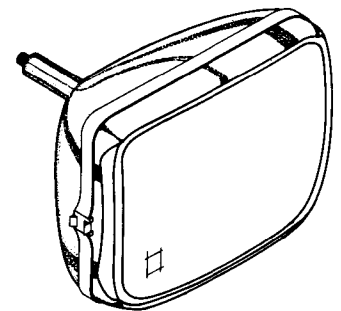

**SYLVANIA
ELECTRONIC TUBES**

A Division of
 Sylvania Electric Products Inc.

**PICTURE TUBE
OPERATIONS
SENECA FALLS, NEW YORK**

Prepared and Released By The
 TECHNICAL PUBLICATIONS SECTION
 EMPORIUM, PENNSYLVANIA

SEPTEMBER, 1963

PAGE 1 OF 3

File Under

TELEVISION PICTURE TUBES

MAXIMUM RATINGS (Design Maximum Values) (Cont'd)

Cathode Drive Service⁴		
Maximum Anode Voltage	22,000 Volts	dc
Minimum Anode Voltage	11,000 Volts	dc
Grid No. 4 Voltage (Focusing Electrode)	-400 to +1250 Volts	dc
Maximum Grid No. 2 Voltage	700 Volts	dc
Minimum Grid No. 2 Voltage	350 Volts	dc
Cathode Voltage		
Positive Bias Value	155 Volts	dc
Positive Peak Value	220 Volts	
Negative Bias Value	0 Volt	dc
Negative Peak Value	2 Volts	
Peak Heater-Cathode Voltage		
Heater Negative with Respect to Cathode		
During Warm-up Period Not to Exceed 15 Seconds	450 Volts	
After Equipment Warm-up Period	200 Volts	
Heater Positive with Respect to Cathode		
	200 Volts	

TYPICAL OPERATING CONDITIONS

Grid Drive Service³		
Anode Voltage	18,000 Volts	dc
Grid No. 4 Voltage for Focus	0 to 400 Volts	dc
Grid No. 2 Voltage	400 Volts	dc
Grid No. 1 Voltage Required for Cutoff ⁵	-46 to -94 Volts	dc
Cathode Drive Service⁴		
Anode Voltage	18,000 Volts	dc
Grid No. 4 Voltage for Focus	0 to 400 Volts	dc
Grid No. 2 Voltage	400 Volts	dc
Cathode Voltage Required for Cutoff ⁵	42 to 78 Volts	dc

CIRCUIT VALUES:

Grid No. 1 Circuit Resistance	1.5 Megohms Max.
---	------------------

NOTES:

1. Heater warm-up time is defined as the time required for the voltage across the heater to reach 80 % of its rated value after applying four (4) times rated heater voltage to a circuit consisting of the tube heater in series with a resistance equal to three (3) times rated heater voltage divided by rated heater current.
2. External conductive coating and rim band must be grounded.
3. Voltages are positive with respect to Cathode unless indicated otherwise.
4. Voltages are positive with respect to Grid No. 1 unless indicated otherwise.
5. Visual extinction of focused raster. For cutoff of the undeflected spot, the absolute value of the bias between cathode and grid will increase by about 5 volts.

WARNING:

X-ray radiation shielding may be necessary to protect against possible danger of personal injury from prolonged exposure at close range if this tube is operated at higher than the manufacturer's Maximum Rated Anode Voltage or 16,000 volts, whichever is less.

OUTLINE

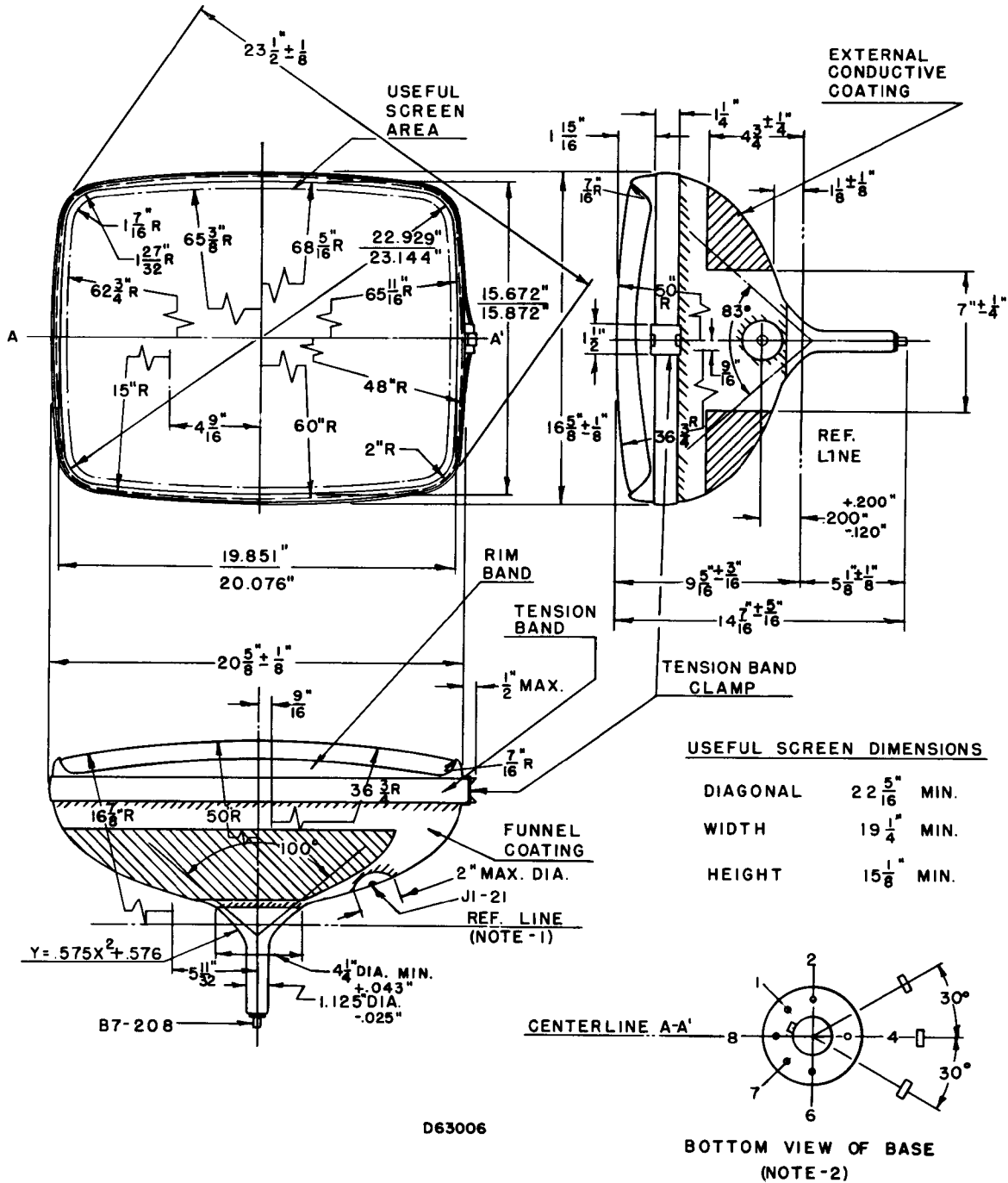

DIAGRAM NOTES:

1. Reference line is determined by plane C-C' of JEDEC No. 126 Reference Line Gauge, when the gauge is seated against the bulb.
2. Base Pin No. 4 aligns with horizontal centerline (A-A') within 30° and is on same side as anode contact, J1-21.