

from JETEC release
#1627, April 9, 1956

REFLEX KLYSTRON

(MECHANICALLY TUNED)

DESCRIPTION

The 6541 reflex klystron (Bendix Type TE-30) is a ruggedized, low voltage, mechanically tuned K-band reflex oscillator designed for use as a CW power source over the frequency range of 23.25 KMC/sec. to 24.75 KMC/sec. This tube incorporates an improved method of tuning the cavity resonator which permits the achievement of a relatively flat power output and electronic tuning characteristic with variation of the operating frequency. Unlike the conventional capacitive type tuners wherein the interaction gap spacing of the resonant cavity is varied to control the operating frequency, the interaction gap of the type 6541 is fixed at optimum spacing. Tuning is accomplished by moving a dielectric rod into the electric field surrounding the interaction gap. The tuner rod is moved by a spring loaded differential screw acting through bellows in the wall of the vacuum envelope. This screw is designed to receive an allen wrench for tuning purposes and can be locked in position with an external lock nut. Since a flexible diaphragm is no longer necessary as a cavity wall for tuning purposes, the cavity is designed as a rigid structure which is stable under acceleration, shock, and vibration environments. The electron gun and repeller structures are mounted rigidly on ceramics in order to ruggedize these assemblies and to eliminate the use of all mica insulators which are subject to decomposition and flaking under severe environmental conditions. The output coupling is accomplished by means of an internal tapered section of waveguide which couples radio frequency energy from the cavity resonator through a non-resonant iris. This waveguide section tapers in the narrow dimension only from the iris to a terminating choke abutting a circular low loss glass output window. The output fitting of the tube is designed to match and fasten directly to a standard UG-596/U waveguide choke flange. The bulb is of steel construction and hence provides protection from external magnetic fields for the internal electron optics structure.

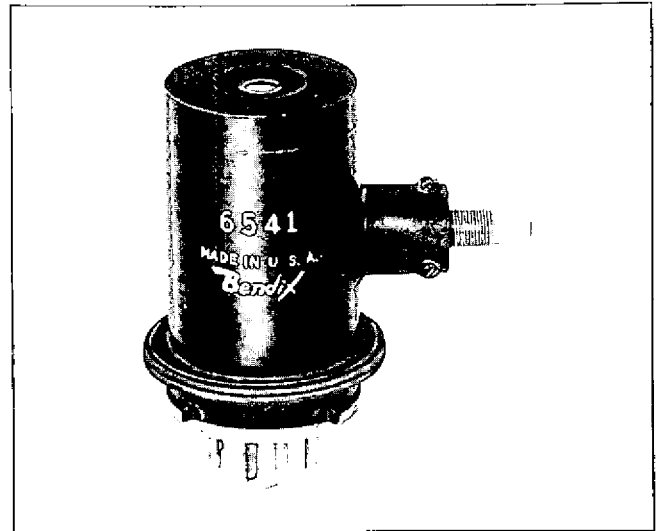

Output Load The tube has been designed for operation into a matched waveguide load. When operation into a reactive load is necessary, adequate attenuation should be inserted in the load circuit between the tube and the load to limit the voltage standing wave ratio at the tube to a value less than 2 to 1 in order to prevent impairment of tube performance.

Repeller Modes The tube should be operated in the repeller voltage mode defined in this data sheet. However, modes do exist at lower repeller voltages than that specified which should be considered when the design of AFC circuits is undertaken to prevent lock-in on one of these lower modes. The 6541 has been designed to provide a minimum mode separation of 40 volts between the operating repeller voltage mode and the next lower mode.

APPLICATION NOTES

Insulation The bulb of the 6541 is designed to operate at resonator voltage potential hence requiring a resonator voltage supply having its positive polarity grounded when the tube is to be mounted directly on the waveguide flange. If the desired application requires that the tube shall be operated above ground or "hot" with respect to ground, the tube and the waveguide flange may be insulated by means of a mica sheet and four insulating bushings between the mounting screws, tube and waveguide flange.

Cooling The maximum bulb temperature should not exceed 130°C in applications where long tube life is important. At room temperature without a tube enclosure no forced cooling is required. If the tube is to be operated in an enclosure, care should be taken to insure that adequate cooling is provided in order that the maximum bulb temperature is not exceeded since impairment of tube life may result.

Environment The type 6541 has been designed to provide stable frequency and power output under severe acceleration, shock, and vibration environments. Under constant acceleration up to 50G, impact shocks of 5 milliseconds duration to 100G, and vibration environments at 10 to 1200 cycles/sec. with accelerations of 3 to 10G, the tube displays maximum variations in power output of 10%, maximum frequency modulation of 2 Mc/sec., and maximum frequency variations of 5 Mc/sec.

MAXIMUM RATINGS

(ABSOLUTE VALUES)

Filament Voltage	6.3 ± 8% volts
Resonator Voltage	330 volts D.C.
Reflector Voltage	-300 volts D.C.
Resonator Current	30 mA dc
Heater-Cathode Voltage	± 45 volts

PHYSICAL CHARACTERISTICS

- **Dimensions:** Refer to the outline drawing.
- **Weight:** 4.3 ounces.
- **Base:** Small Octal 8-Pin, B8-21, Low Loss Phenolic Wafer.
- **Coupling to Wave Guide:** Direct. Fastens to UG-596/U choke flange.
- **Cooling:** Convection.
- **Mounting Position:** Any.
- **Cavity:** Silver Plated Steel.
- **Bulb:** Metal.
- **Output Window:** Low Loss Glass.

RED BANK DIVISION
BENDIX AVIATION CORPORATION
EATONTOWN, NEW JERSEY

AVERAGE CHARACTERISTICS

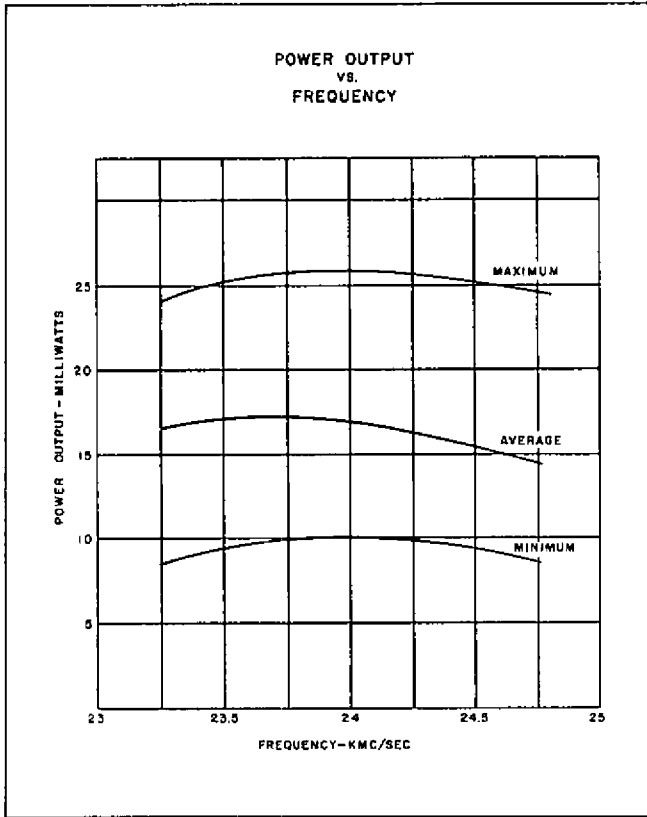

POWER OUTPUT VS. FREQUENCY

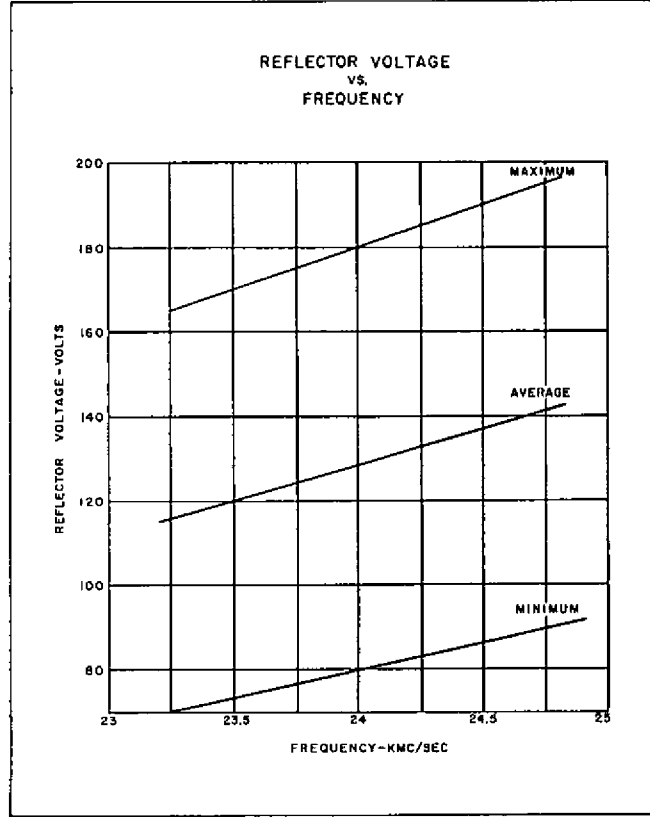

REFLECTOR VOLTAGE VS. FREQUENCY

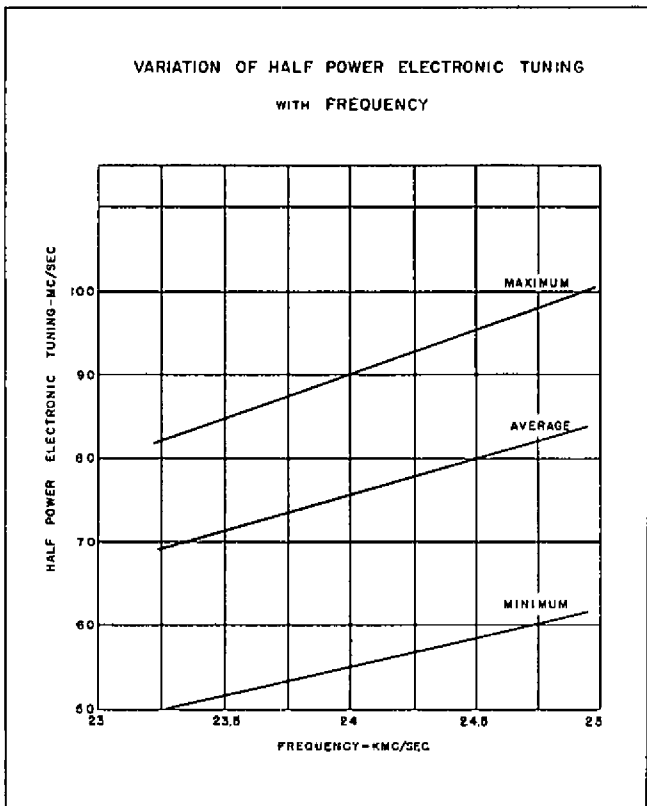

ELECTRONIC TUNING VS. FREQUENCY

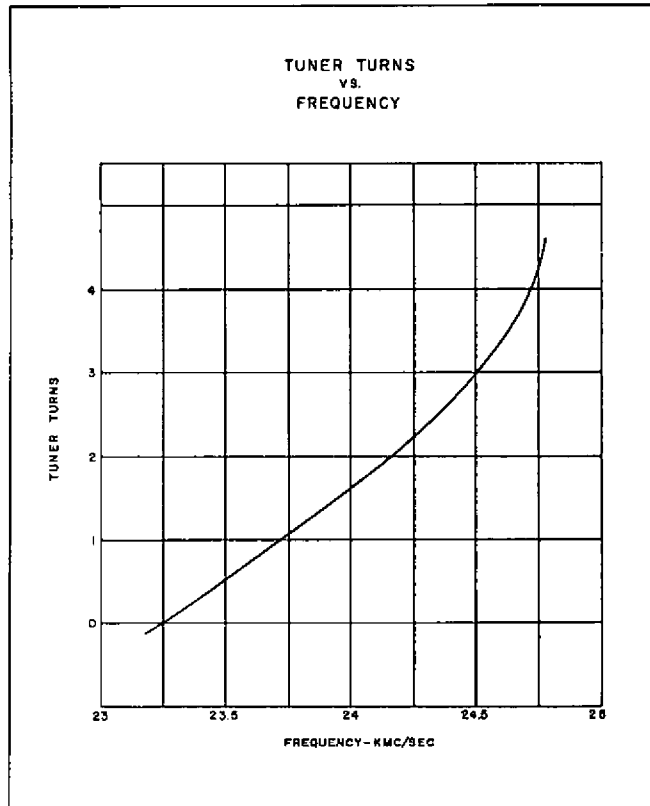

TUNER TURNS VS. FREQUENCY

ELECTRICAL CHARACTERISTICS & TEST CONDITIONS

Test Conditions and Specification Limits

TEST	CONDITIONS	SYMBOL	LIMITS		UNITS
			MIN.	MAX.	
PRODUCTION TESTS:					
Total Reflector Current	$E_r = -100$ Vdc	I_r	—	7.0	μ Adc
Reflector Leakage Current	$E_r = -100$ Vdc		—	5.0	μ Adc
Reflector Gas Current	$E_r = -100$ Vdc		—	2.0	μ Adc
Resonator Current	Test Conditions; $E_r = -100$ Vdc	I_{rs}	—	30	mAdc
Mechanical Tuning Range	$E_r/\max P_o$	F	23250	24750	Mc
Power Output (1)	Test Conditions	P_o	10	—	mW
Power Output (2)	$E_r/\max P_o$; $F = 23250 \pm .3\%$; $F = 24750 \pm .3\%$	P_o	8.5	—	mW
Reflector Voltage	Test Conditions; $E_r/\max P_o$	E_r	-80	-180	Vdc
Electronic Tuning (1)	Test Conditions; $E_r/50\%$ $\max P_o$		55	—	Mc
Emission	$E_f = 5.8$ v	$\Delta I_k/I_k$	—	15	%
Hysteresis	Test Conditions; $E_r/\max P_o$	Ratio	—	5	%
DESIGN TESTS:					
Insulation	$E_{hk} = \pm 45$ Vdc	I_{hk}	—	100	μ Adc
Heater Current	Test Conditions	I_f	475	555	mA
Bump	Test Conditions; $E_r/\max P_o$	$\Delta P_o/P_o$	—	0.10	
Electronic Tuning (2)	$F = 23250 \pm .3\%$; $F = 24750$ $\pm .3\%$; $E_r/50\% \max P_o$		55	—	Mc
Modulation Sensitivity Resonator	Test Conditions; $\Delta E_{rs} = 20$ Vac	$\Delta f/\Delta E_{rs}$	1.0	1.6	Mc/v
Modulation Sensitivity Repeller	Test Conditions; $\Delta E_{rp} = \pm 3$ v	$\Delta f/\Delta E_{rp}$	2.0	4.0	Mc/v
Life Test	Test Conditions	t	500	—	hrs
Life Test End Points	Test Conditions	P_o	8	—	mW

GENERAL TEST CONDITIONS:

E_f	E_{rs}	E_r	F
6.3 volts	+300 Vdc	Adjust	$24000 \pm 0.3\%$ Mc

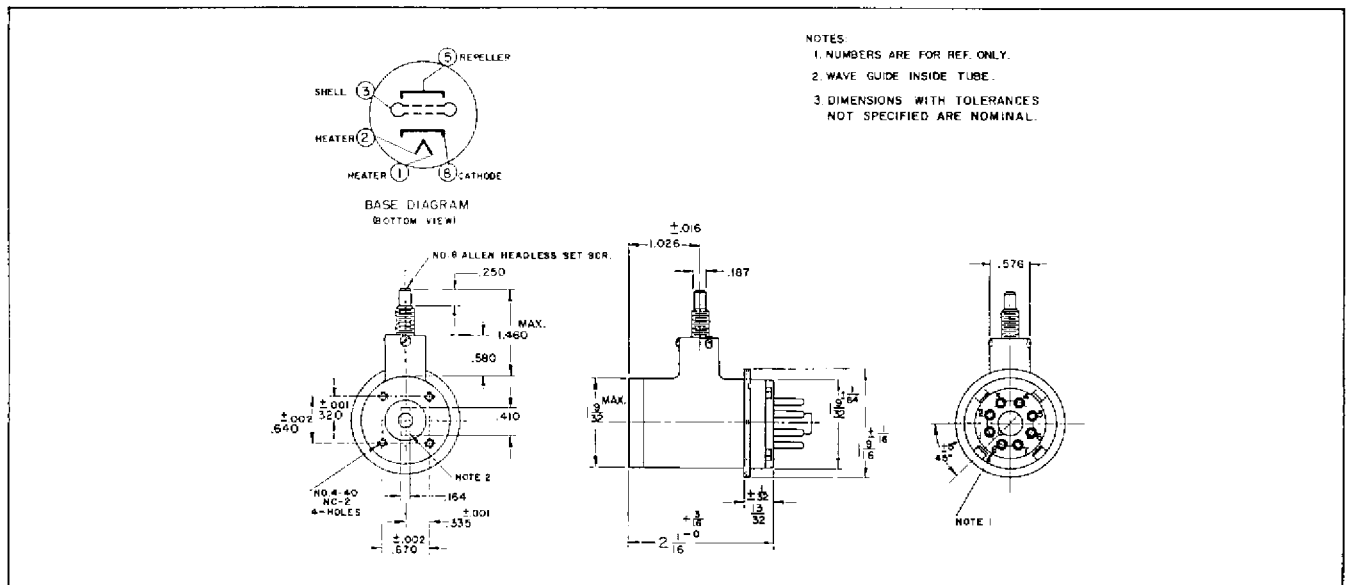

OUTLINE DRAWING

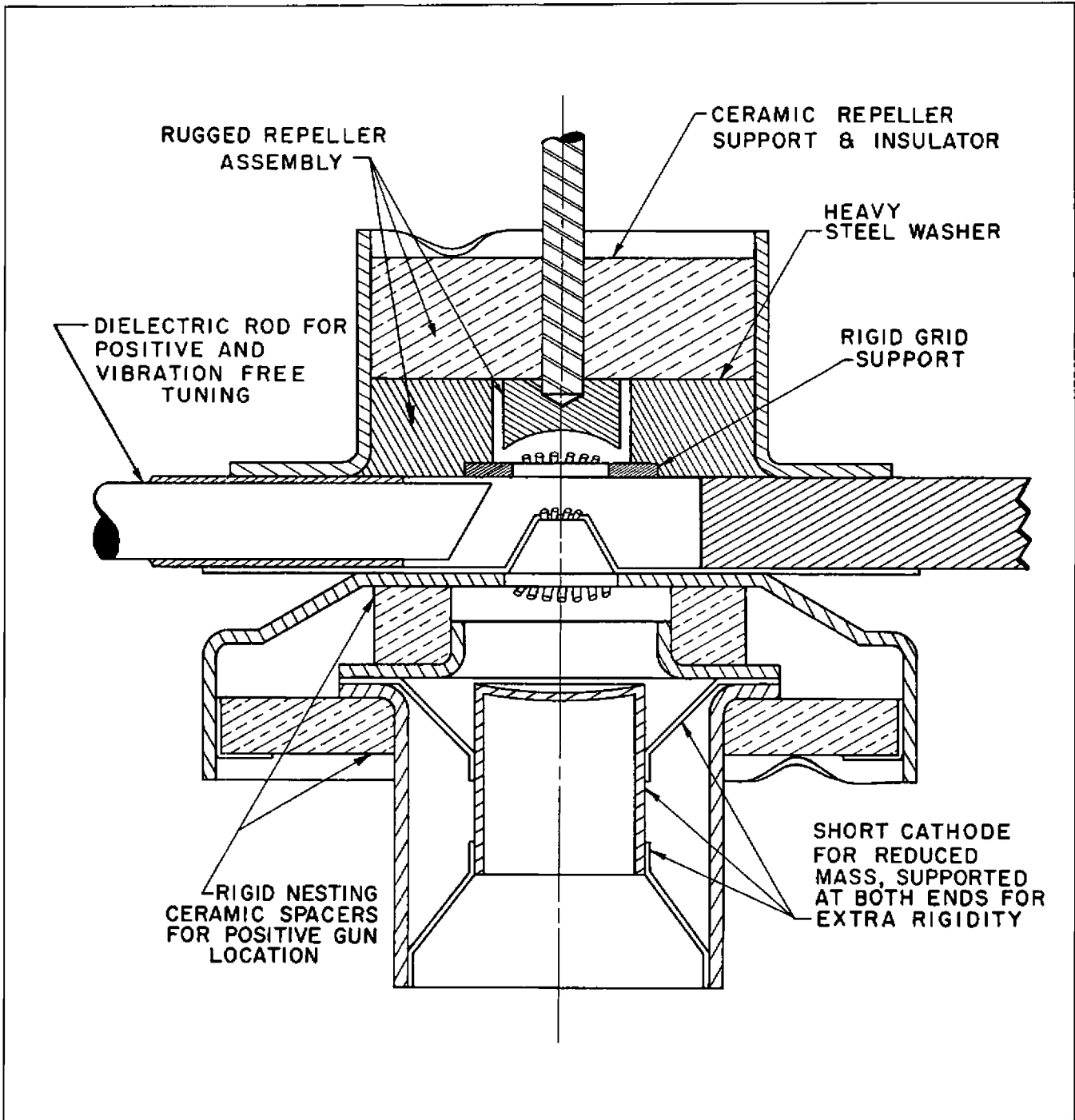

STRUCTURAL FEATURES OF THE 6541

RED BANK DIVISION
BENDIX AVIATION CORPORATION
EATONTOWN, NEW JERSEY



Printed in U.S.A.

West Coast Sales and Service: 117 E. Providencia, Burbank, Calif.
Export Sales: Bendix International Division, 205 E. 42nd St., New York 17, N. Y.
Canadian Distributor: Aviation Electric Ltd., P.O. Box 6102, Montreal, P. Q.